

# Highly performance & reliable

## **NEO-Sunny** *Petrol Pump & Dispenser*

- Accuracy & Durably
- Global Standard
- Rich in Function Designed and Latest Technology
- Easy Operation and Maintenance
- Large Easy to see with LCD Display
- Easy to Set Preset Function

Equipped with reliable,  
high precision  
TATSUNO pump & meter  
remote control



 **TATSUNO**  
CORPORATION

# NEO-Sunny

## Petrol Pump & Dispenser

### Types

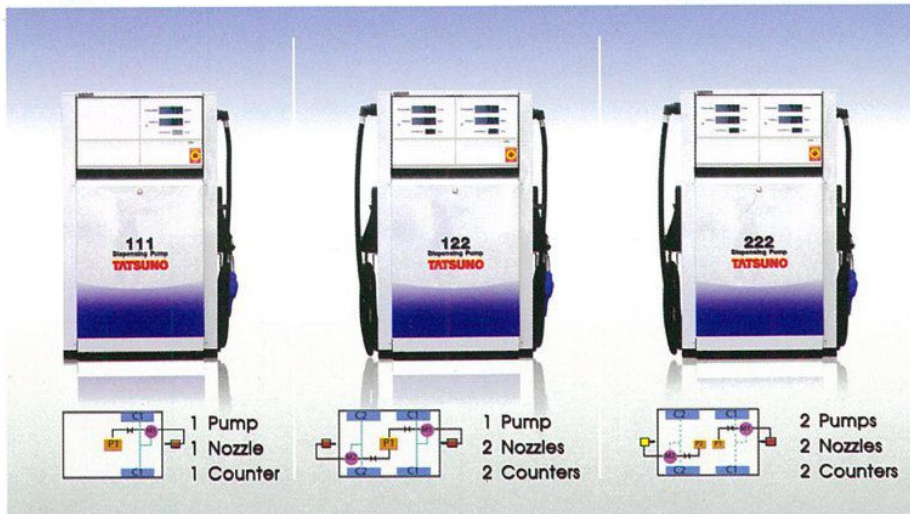

### Dimensions

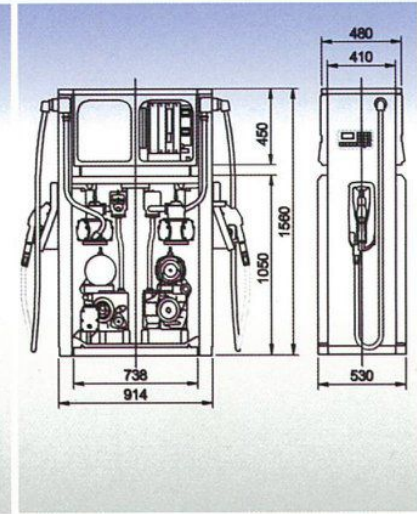

### Specifications

<b>Model Name &amp; Type</b> GDA suction type GSA remote type	GDA / GSA models: Island Oriented (Nozzle side model), Narrow body without top case
<b>Delivery Speed</b>	Suction models: Standard speed (Gasoline/Diesel): 40 liters/min. Note: Simultaneous fueling 30 or 35 liters/min. at standard speed Remote models: depend on a capacity of installed submersible pump at site.
<b>Measuring Accuracy</b>	± 0.25 %
<b>Flow Meter</b>	4-piston type positive displacement flow meter & electric calibration system
<b>Suction pumping Unit</b>	Internal silent gear pump with air separator, by-pass valve and suction strainer & check valve
<b>Motor</b>	1-phase Induction motor, Explosion-proof, 220 VAC ± 10% 50/60Hz, 3/4 HP
<b>Counter</b>	<ul style="list-style-type: none"> <li>1) Type: LCD (Liquid Crystal Display)</li> <li>2) Character color: Black characters on white field with bright LED back light</li> <li>3) Display: Cash-6 digits H: 35 mm, Volume-6 digits H: 35 mm, Unit price-4 digits H: 22mm</li> <li>4) Unit price setting: By remote controller</li> <li>5) Electronic totalizer: 8 + 2 digits</li> <li>6) Other functions: Self-diagnosis function, Battery back-up, Over voltage protector</li> </ul>
<b>Preset</b>	Display use for confirming the preset data with small LCD Display Function: Presettable for amount and volume with ten(10) keypad + 5-rank one-touch key buttons (Possible combined setting between amount & volume)
<b>Totalizer</b>	Electro-magnetic type: 7 digits (Volume for each hose) combined with Standard or Optional flow meter.
<b>Reset Device</b>	Automatic reset in nozzle holder.
<b>Nozzle</b>	TATSUNO Nozzle with color scraf guard Spout size: 13/16" or 15/16"
<b>Swivel</b>	Provided: Single plane swivel
<b>Hose</b>	Black color, 3/4" x 15FT, Oil resistance type
<b>Safety Breakaway Coupling</b>	Option
<b>Filter for remote models</b>	Paper filter type
<b>Painting</b>	White
<b>Product sticker</b>	Not provided
<b>POS Interface</b>	Option
<b>Emergency Stop button</b>	Provided

Note: The delivery speed of the pump may change due to the following conditions if it beyond TATSUNO's installation and operational instructions:

- 1) Size and length of hose
- 2) Size and Type of Nozzle / Swivel
- 3) Oil products, suction and local piping conditions
- 4) With / without present (Specifications are subject to change with or without prior notice)



บริษัท ทัทซุโน เอ็นจิเนียริ่ง แอนด์ เซอร์วิส จำกัด  
TATSUNO Engineering & Service Co., Ltd.  
19/79 หมู่ 18 ถนนลำลูกกา ตำบลคูคต อำเภอลำลูกกา จังหวัดปทุมธานี 12130  
Tel. 02-5320987, 02-9959528 Fax. 02-9959529  
E-mail: sales@tatsuno.co.th www.tatsuno.co.th

